



APPLICATION NOTE 4111

Eliminating Ghost-Image Currents in Color-LED Display Systems Using the MAX6972–MAX6975 LED Drivers

Abstract: Multiplexing LED drivers helps increase efficiency and reduce cost; however, designing multiplexed-LED circuits can be tricky. Improperly designed circuits can lead to undesired LED currents and image artifacts in the application. This application note details the problems associated with multiplexing LEDs and explains how these obstacles can be overcome by utilizing the MAX6972–MAX6975 family of pulse-width-modulated LED drivers for message boards.

Note: The suffix "-bar" (MUX1-bar and MUX0-bar) indicates the active-low functionality of pins MUX1 and MUX0.

Introduction

The MAX6972–MAX6975 are constant-current LED drivers for high-speed multicolor and video display boards. The [MAX6972/MAX6973](#) drive 16 LEDs directly or 32 LEDs when multiplexed, while the [MAX6974/MAX6975](#) drive 24 LEDs directly or 48 LEDs when multiplexed. The advantage of multiplexed operation is that it doubles the number of LEDs per driver and, therefore, provides substantial cost savings.

However, improperly designed LED-multiplexing circuits can create ghost images. Ghost images result when parasitic current flows through LEDs that are intended to be in an off state (i.e. no current flowing through them); this causes very faint illumination or ghosting. These ghost-image currents typically result from the discharging of stray capacitances associated with the large, common-LED anode-node tracks and the slightly forward-biased LEDs themselves. With careful multiplexer-circuit design, the MAX6972–MAX6975 family of constant-current LED drivers can prevent these ghost-image artifacts in display systems.

Typical Multiplexing Circuit

Figure 1 illustrates the typical multiplexing circuit used for the MAX6972–MAX6975 (refer also to the [MAX6972](#) and [MAX6974](#) EV Kits).

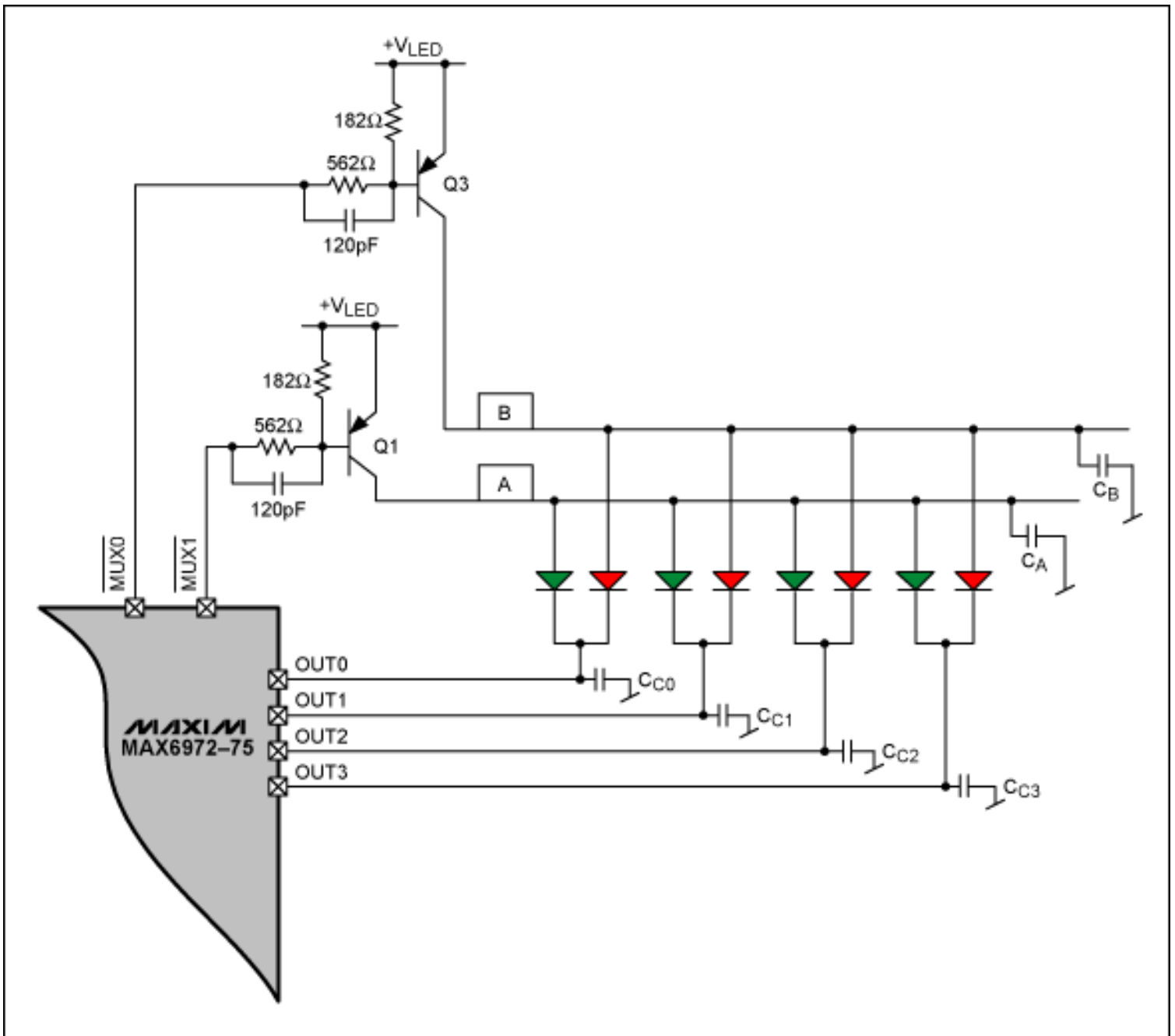

Figure 1. Typical multiplexing circuit with red LEDs driven by MUX0-bar and green LEDs driven by MUX1-bar.

The multiplexing transistors (Q1 and Q3) are alternately turned on by the MAX6972–MAX6975 while the constant-current-sinking drive pins (OUT0–OUTn) alternate control settings between the two phases. During Phase 1, MUX1-bar is low, Q1 is turned on, and node A is pulled to V_{LED} , thereby connecting all of the green-LED anodes to the LED supply. Likewise, during Phase 0, MUX0-bar is low and Q3 is turned on, connecting all of the red LEDs to the V_{LED} supply. The MUX0-bar and MUX1-bar outputs turn on the pnp transistors by sinking base current through the 562Ω resistors via their open-drain drivers. When MUX0-bar and MUX1-bar are off, the open-drain outputs are essentially open-circuit, allowing the base-emitter resistors (182Ω each) to turn off the pnp transistors. Between each MUX0-bar and MUX1-bar phase, both Q1 and Q3 are off for 16 periods of the internal clock (CLK1), which is shown as t_{EMUX} in Figure 2.

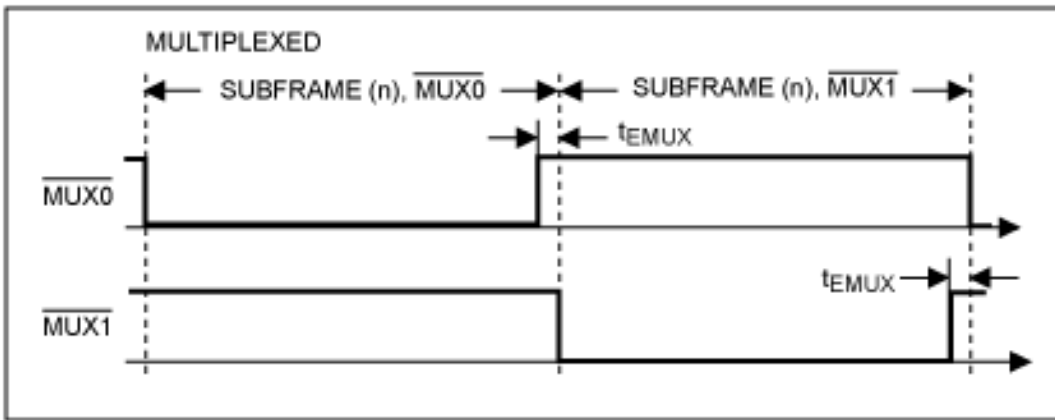

Figure 2. Multiplex timing for the MAX6972–MAX6975.

Ghost-Image Currents in the Typical Circuit

Faint ghosting images from parasitic currents can occur when the multiplexing changes phases from MUX0-bar to MUX1-bar and vice versa. The effect is most pronounced when the LEDs on the multiplexed circuits are different colors (light wavelengths) and, hence, have significantly different voltage drops for a given current flow.

For the sake of clarity, the Figure 1 multiplexing circuit is simplified in the remaining discussion to show only one red and one green LED. In the following examples, a red LED is driven by MUX0-bar through Q3 and a green LED is driven by MUX1-bar through Q1.

The voltage drops for the LEDs are:

$$V_{RED} = 2.0V$$

$$V_{GREEN} = 3.1V$$

The power supplies are:

$$V_{+} = 3.3V$$

$$V_{LED} = 5.0V$$

The parasitic current flow that results from multiplexing LEDs with different forward-voltage drops is best illustrated starting with Phase 0, in which MUX0-bar is asserted low and the red LED is illuminated (**Figure 3**).

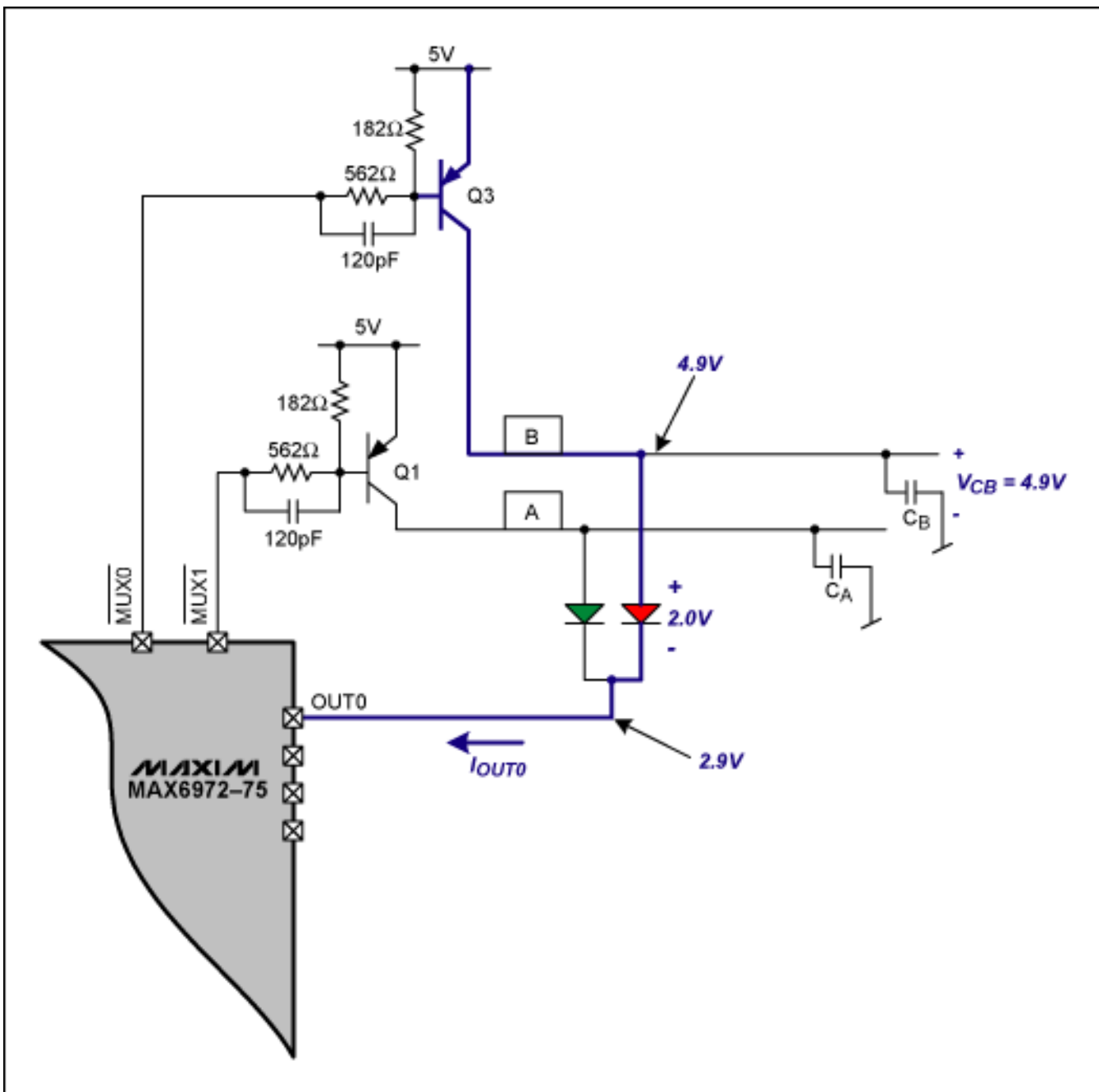

Figure 3. A red LED illuminated during Phase 0 with MUX0-bar asserted low.

With Q3 turned on, the anode of the red LED (node B) is pulled up to 4.9V. Current flows through the red LED and the constant-current driver (OUT0) for the port that is active (i.e. the channel driving the LED for any amount of the PWM cycle). The parasitic capacitance of node B (shown as a lumped parameter, C_B) is charged to 4.9V. The LED cathode node is forced to a voltage approximately equal to:

$$4.9V - V_{RED} = 2.9V \quad (\text{Eq. 1})$$

When Phase 0 ends, the OUT0 driver is inactive and MUX0-bar goes high (inactive), disconnecting the anode voltage from the LED supply. The voltage across the red-LED PN junction remains close to the forward-voltage drop of 2.0V since there is no discharge path. Likewise, the voltage V_{CB} on the parasitic node capacitance remains at 4.9V since there is no discharge path. This voltage condition persists through the interphase period of 16 CLKI cycles.

When Phase 1 begins, MUX1-bar is asserted low, Q1 turns on, the anode of the green LED is connected to 5V, and the OUT0 current driver is activated for the selected LED. The final steady-state condition is shown in **Figure 4**.

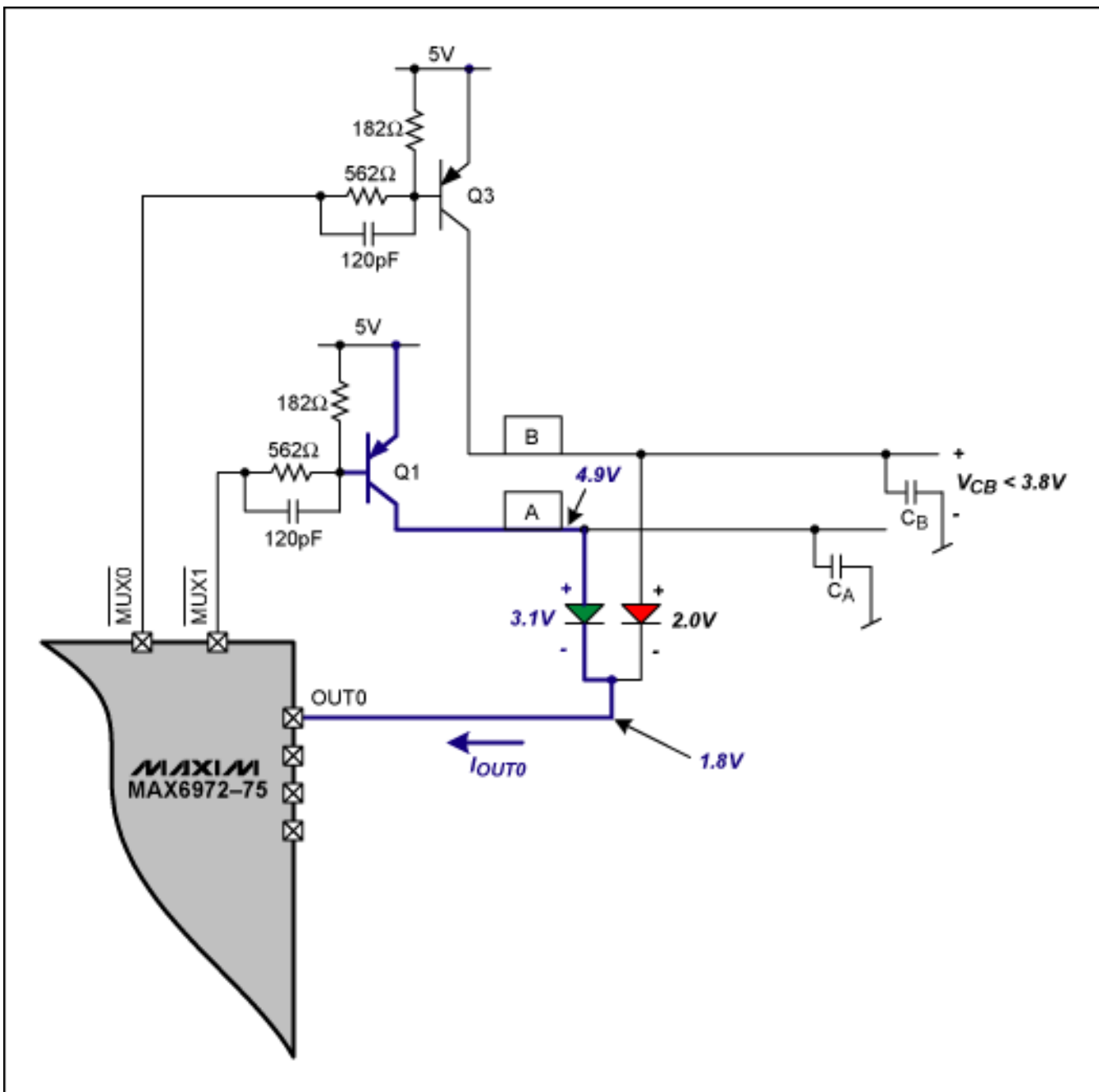

Figure 4. A green LED illuminated during Phase 1 through Q1 and OUT0.

The cathode node voltage is lower with the green LED's higher voltage drop, which is approximately equal to:

$$4.9V - V_{\text{GREEN}} = 1.8V \quad (\text{Eq. 2})$$

A voltage of 1.8V on the cathode of the red LED means the anode can be no higher than $1.8V + V_{\text{RED}} = 3.8V$. At the beginning of Phase 1, the common-cathode node voltage (the voltage of OUT0 in the figures) has to change from 2.9V to 1.8V. This change in voltage requires the discharging of C_B from 4.9V to a value of 3.8V or less. The current discharging C_B flows through the red LED, as shown in **Figure 5**, causing a faint flicker of illumination.

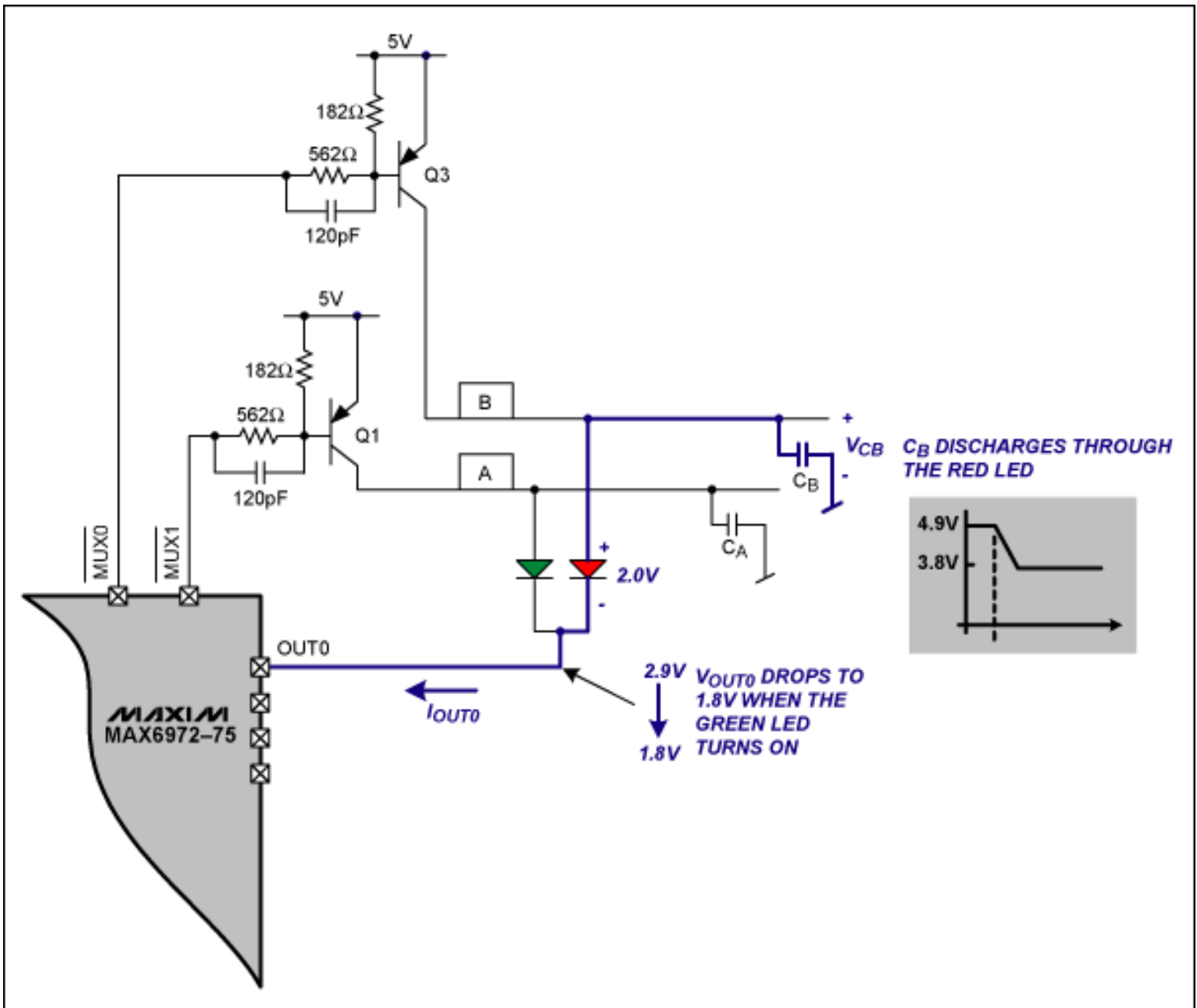

Figure 5. The discharge path for parasitic node capacitance C_B through the red LED causes a faint flicker of illumination during the multiplex transition from Phase 0 to Phase 1.

The current discharging C_B occurs regardless of whether the red LED was on or off in the previous phase. The voltage on node B is always charged to 4.9V during Phase 0. Node B will discharge through the red LED in conditions where V_{RED} is smaller than V_{GREEN} due to the shared common-cathode connections. This discharging of C_B may cause faint illumination of one or more red LEDs in Figure 1, depending on the slight differences in forward-voltage drops of the various LEDs.

Eliminating Ghost-Image Currents

The ghost-image currents can be eliminated by providing a discharge path for the parasitic node capacitances and providing a time for the discharge to occur. This is accomplished by adding resistors R1 and R2, as shown in Figure 6. The resistor values are chosen to provide adequate discharge during the idle period between multiplex phases.

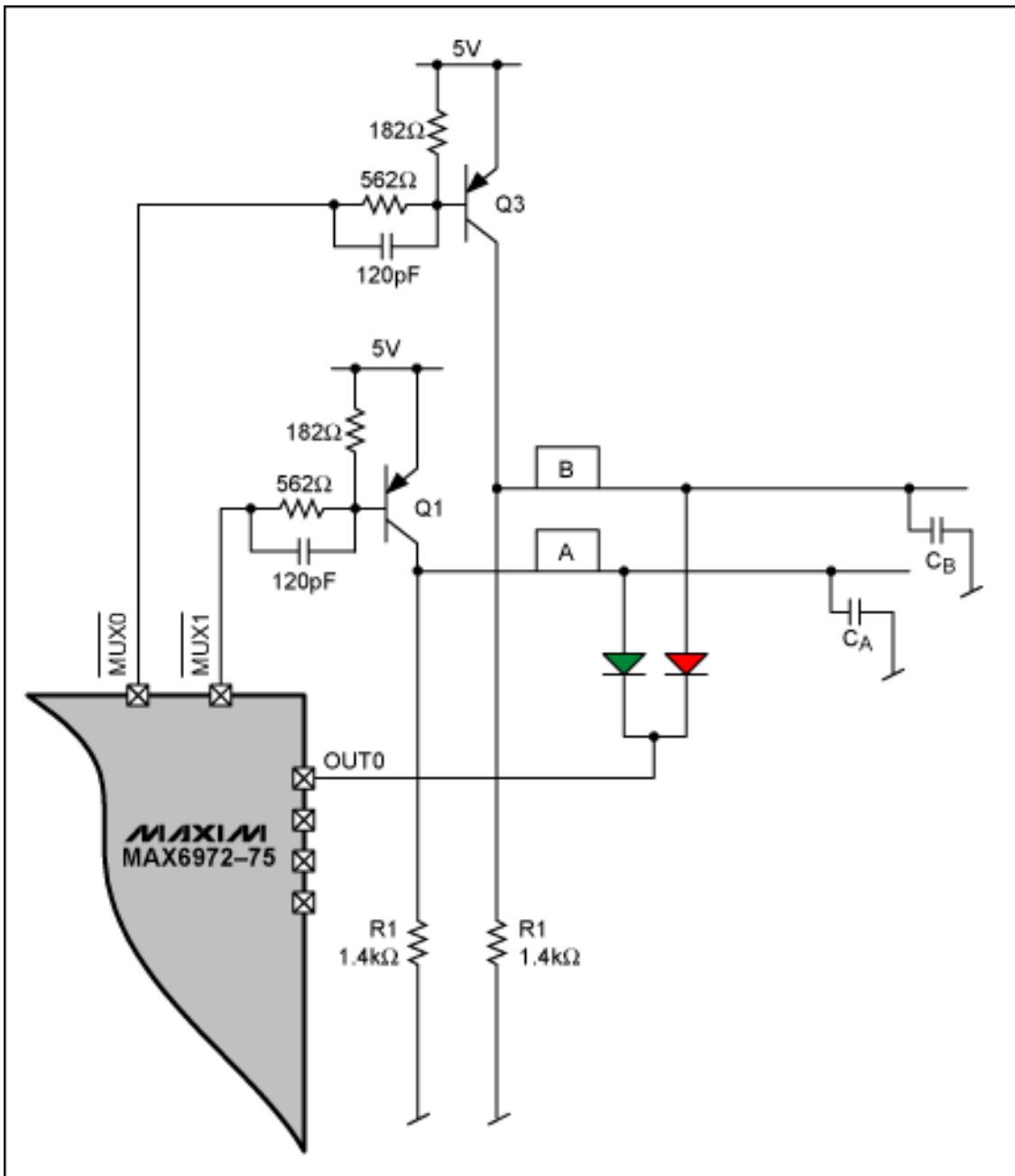

Figure 6. Adding resistors R1 and R2 provides discharge paths for parasitic node capacitances C_B and C_A.

Resistors R1 and R2 are sized to discharge the anode nodes A and B during the interphase intervals to prevent forward biasing of the LEDs when the next active phase begins. In the example shown, node B must be discharged from 4.9V to a value less than 3.8V before Phase 1 begins.

The interphase time is governed by the system clock frequency, which can be operated at a maximum of 33MHz. Using this maximum frequency, the value of R2 can be determined.

The interphase time (t_{EMUX} in Figure 2) is derived from the system clock frequency:

$$t_{CLKI} = 1/33\text{MHz} = 30.3\text{ns} \quad (\text{Eq. 3})$$

and

$$t_{EMUX} = 16 \times t_{CLKI} = 485\text{ns} \quad (\text{Eq. 4})$$

A nominal parasitic anode-node capacitance can be estimated by taking 150pF per LED (derived from the combined capacitances of traces, package leads, and marginally biased LED PN junctions) and multiplying by eight LEDs per node:

$$C_B = C_A = 150\text{pF} \times 8 = 1.2\text{nF} \quad (\text{Eq. 5})$$

The current required to discharge C_B during the interphase period can be estimated by:

$$I_{\text{DIS}_B} = C_B \times \Delta V_{C_B} / \Delta t \quad (\text{Eq. 6})$$

By plugging the numbers above into this equation, we can approximate the discharge current required by C_B :

$$I_{\text{DIS}_B} = 1.2\text{nF} \times (4.9\text{V} - 3.8\text{V}) / 485\text{ns}$$

$$I_{\text{DIS}_B} = 2.7\text{mA}$$

A resistor value to produce a nominal discharge current of 2.7mA at the lowest voltage in the range of interest is:

$$R_2 = 3.8\text{V} / 2.7\text{mA} \quad (\text{Eq. 7})$$

$$R_2 = 1.4\text{k}\Omega$$

The same calculation can be made for I_{DIS_A} and C_A . However, the affect of the ghost-image current is different for the transition of phases from Phase 1 to Phase 0 due to the LED forward-voltage drops not having the same effect. It can be shown that no ghost-image current will occur in the Phase 1 to Phase 0 transition in the Figure 6 circuit. However, R_1 is included with the same value as R_2 , which allows for cases where the red and green LEDs are mixed alternately between MUX0-bar and MUX1-bar phases.

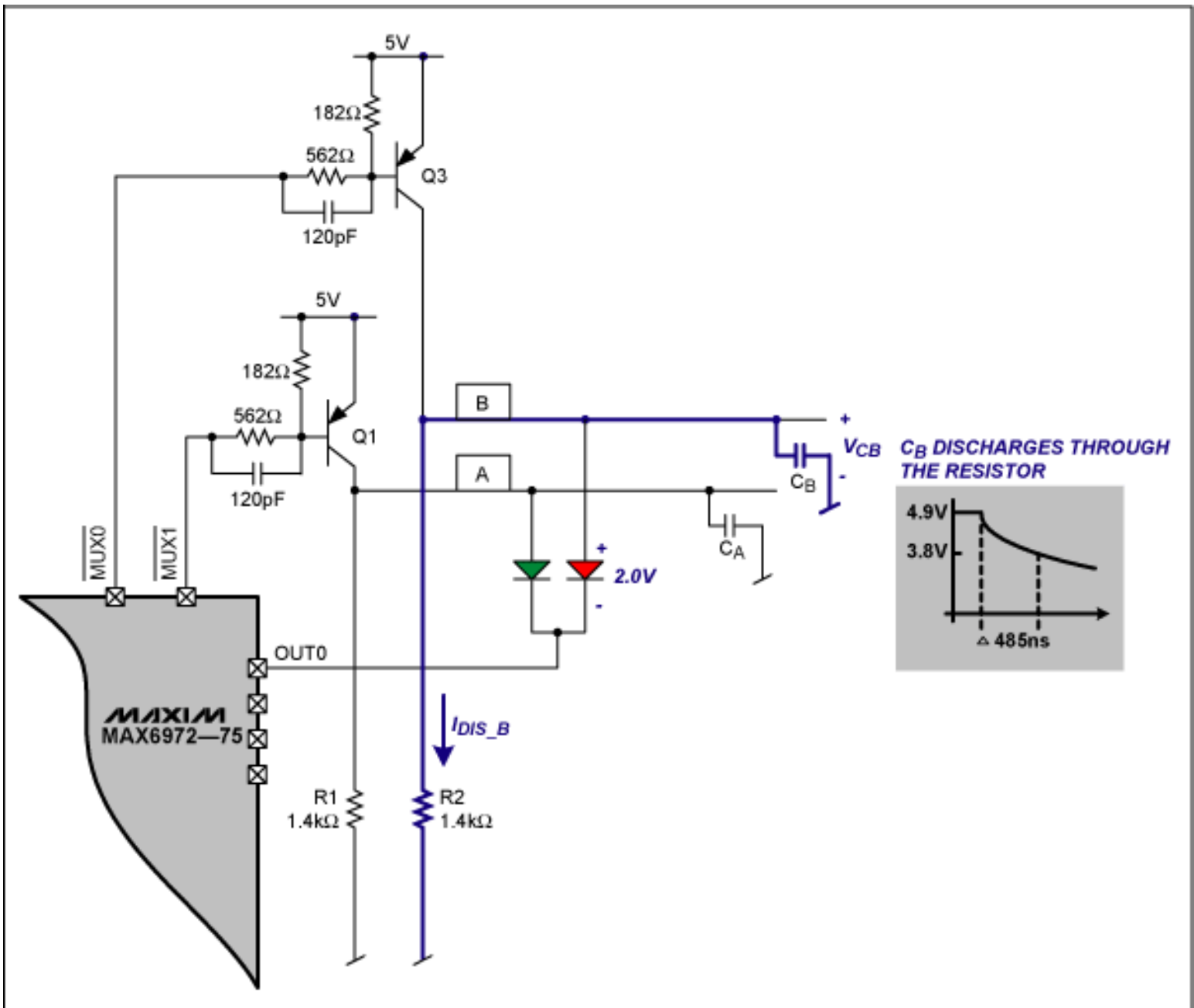

Figure 7. Parasitic capacitance C_B is discharged through R_2 during the interphase null time t_{EMUX} without disturbing the calibrated constant drive through the LEDs.

Resistors R_1 and R_2 add a small current load to the multiplexing transistors Q_1 and Q_3 during each phase:

$$I_{Rn} = 4.9V/1.4k\Omega = 3.5mA \quad (\text{Eq. 8})$$

This current does not flow through the constant-current driver output OUT_0 or through the LEDs, and, hence, it does not disturb the calibrated LED currents.

Conclusion

The MAX6972–MAX6975 multiplexing circuits provide a guaranteed interphase dwell time that can be used to discharge parasitic node capacitances and thereby eliminate ghost-image currents in multiplexed display systems. The addition of two resistors per MAX6972–MAX6975 device is a minimal cost to incur in order to ensure sharp display pictures and graphics that are free of ghost-image artifacts.

Application Note 4111: <http://www.maxim-ic.com/an4111>

More Information

For technical questions and support: <http://www.maxim-ic.com/support>

For samples: <http://www.maxim-ic.com/samples>

Other questions and comments: <http://www.maxim-ic.com/contact>

Related Parts

MAX6972: [QuickView](#) -- [Full \(PDF\) Data Sheet](#)

MAX6973: [QuickView](#) -- [Full \(PDF\) Data Sheet](#)

MAX6974: [QuickView](#) -- [Full \(PDF\) Data Sheet](#)

MAX6975: [QuickView](#) -- [Full \(PDF\) Data Sheet](#)

AN4111, AN 4111, APP4111, Appnote4111, Appnote 4111

Copyright © by Maxim Integrated Products

Additional legal notices: <http://www.maxim-ic.com/legal>