

STD1LNK60Z-based Cell Phone Battery Charger Design

Introduction

This application note is a Ringing Choke Converter (RCC)-based, step-by-step cell phone battery charger design procedure.

The RCC is essential to the self-oscillating fly-back converter, and operates within the Discontinuous Conduction Mode (DCM) and Continuous Conduction Mode (CCM) boundaries without noticeable reverse recovery of the output rectifying diodes. RCC control is achieved by using discrete components to control the peak current mode, so the overall RCC cost is relatively low compared to the conventional Pulse Width Modulation (PWM) IC fly-back converter. As a result, RCC is widely used for low power applications in industry and home appliances as a simple and cost-effective solution.

Figure 1. STD1LNK60Z-based RCC Printed Circuit Board

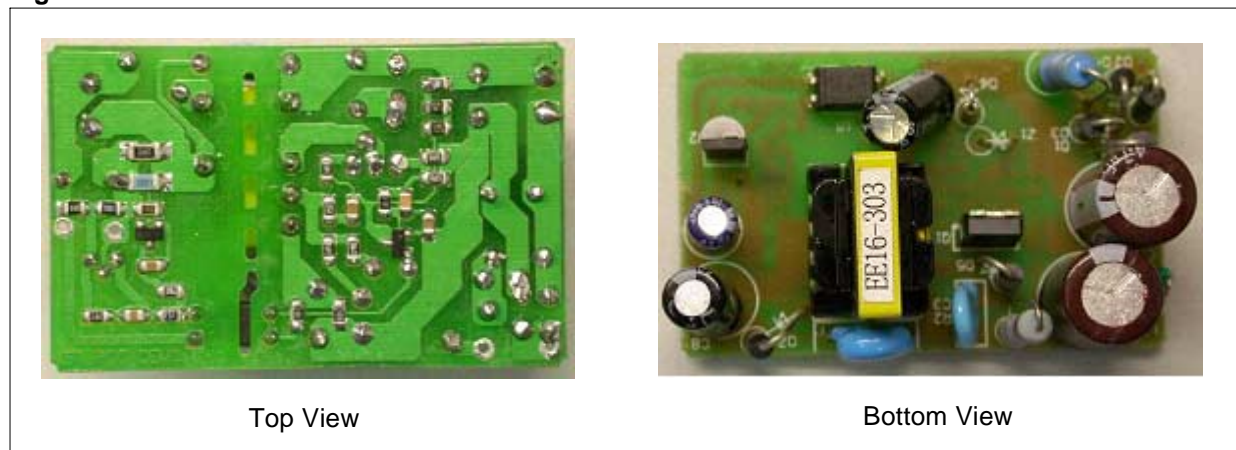

Table of Contents

1	Power Transformer Design Calculations	5
1.1	Switching Frequency	5
1.2	STD1LNK60Z MOSFET Turn Ratio	6
1.3	Primary Current	7
1.4	Primary Inductance	7
1.5	Magnetic Core Size	8
1.6	Primary Winding	8
1.7	Secondary Winding	10
1.8	Auxiliary Winding	10
1.9	Gap Length	11
2	STD1LNK60Z-based RCC Control Circuit Components	12
2.1	MOSFET	12
2.2	R3 Startup Resistor	12
2.3	Optocoupler Power Methods	13
2.4	R7 Sense Resistor	14
2.5	Constant Power Control	15
2.6	Zero Current Sense	16
2.7	Constant Voltage And Constant Current	17
3	Test Results	19
	Appendix A: STD1LNK60Z-based RCC Circuit Schematics	22
	Appendix B: STD1LNK60Z-based RCC Circuit Bill of Materials	23
4	Revision History	25

Figures

Figure 1.	STD1LNK60Z-based RCC Printed Circuit Board	1
Figure 2.	Optocoupler Fly-back Power	13
Figure 3.	Optocoupler Forward Power	13
Figure 4.	Current Sense Circuit	15
Figure 5.	CV and CC Curve at 110V _{AC}	18
Figure 6.	CV and CC Curve at 220V _{AC}	18
Figure 7.	Drain To Source Voltage Operation Waveform, 85V _{AC}	20
Figure 8.	Drain To Source Voltage Operation Waveform, 110V _{AC}	20
Figure 9.	Drain To Source Voltage Operation Waveform, 220V _{AC}	21
Figure 10.	Drain To Source Voltage Operation Waveform, 265V _{AC}	21
Figure 11.	RCC Control Circuit Components Schematic (see Section on page 1)	22
Figure 12.	STD1LNK60Z-based RCC Schematic (full view)	22

Tables

Table 1.	Line and Load Regulation	19
Table 2.	Efficiency Ratings	19
Table 3.	Standby Power	19
Table 4.	BOM	23

1 Power Transformer Design Calculations

- The specifications:
 - $V_{AC} = 85\sim 265V$
- Line frequency: 50~65Hz
 - $V_O = 5V$
 - $I_O = 0.4A$

Taking transient load into account, the maximum output current is set as

$$I_{O(max)} = 1.2I_O = 4.8A$$

1.1 Switching Frequency

The system is a variable switching frequency system (the RCC switching frequency varies with the input voltage and output load), so there is some degree of freedom in switching frequency selection. However, the frequency must be at least 25kHz to minimize audible noise.

Higher switching frequencies will decrease the transformer noise, but will also increase the level of switching power dissipated by the power devices.

The minimum switching frequency and maximum duty cycle at full load is expressed as

$$\begin{aligned} f_{S(min)} &= 50kHz \\ D_{max} &= 0.5 \end{aligned}$$

where the minimum input voltage is 50kHz and 0.5, respectively.

1.2 STD1LNK60Z MOSFET Turn Ratio

The maximum MOSFET drain voltage must be below its breakdown voltage. The maximum drain voltage is the sum of:

- input bus voltage,
- secondary reflected voltage, and
- voltage spike (caused by the primary parasitic inductance at maximum input voltage).

The maximum input bus voltage is 375V and the STD1LNK60Z MOSFET breakdown voltage is 600V. Assuming that the voltage drop of output diode is 0.7V, the voltage spike is 95V, and the margin is at least 50V, the reflected voltage is given as:

$$V_{fl} = V_{(BR)DSS} - V_{margin} - V_{DC(max)} - V_{spk} = 600 - 50 - 375 - 95 = 80V$$

The Turn Ratio is given as

$$N = \frac{N_p}{N_s} = \frac{V_{fl}}{V_{OUT} + V_F} = \frac{80}{5 + 0.7} = 14$$

where,

V_{fl} = Secondary reflected voltage

$V_{(BR)DSS}$ = MOSFET breakdown voltage

V_{margin} = Voltage margin

$V_{DC(max)}$ = Maximum input bus voltage

V_{spk} = Voltage spike

V_f = Voltage drop

N = Turn Ratio

N_p = Primary Winding Turns

N_s = Secondary Winding Turns

1.3 Primary Current

- Primary Peak Current is expressed as:

$$I_{ppk} = \frac{2V_O I_{O(max)}}{\eta D_{max} V_{DC(min)}} = \frac{2 \times 5 \times 0.48}{0.7 \times 0.5 \times 90} = 0.152A$$

- Primary Root Mean Square (RMS) Current is expressed as

$$I_{prms} = I_{ppk} \sqrt{\frac{D_{max}}{3}} = 0.152 \times \sqrt{\frac{0.5}{3}} = 0.062A$$

where,

I_{ppk} = Primary peak current

V_O = Voltage output

$I_{O(max)}$ = Maximum current output

η = Efficiency, equal to 0.7

D_{max} = Maximum duty cycle

$V_{DC(min)}$ = Minimum input bus voltage

I_{prms} = Primary RMS current

1.4 Primary Inductance

Primary Inductance is expressed as

$$L_p = \frac{V_{DC(min)} D_{max}}{f_{s(min)} I_{ppk}} = \frac{90 \times 0.5}{0.152 \times 50} = 5.92mH$$

where,

$V_{DC(min)}$ = Minimum Input DC voltage

$f_{s(min)}$ = Minimum switching frequency

D_{max} = Maximum duty cycle

$f_{s(min)}$ = Minimum switching frequency

I_{ppk} = Primary peak current

For example, if Primary Inductance is set to 5.2mH, the minimum switching frequency is:

$$f_{s(min)} = \frac{V_{IN DC(min)} D_{max}}{L_p I_{ppk}} = \frac{90 \times 0.5}{0.152 \times 5.2} = 57kHz$$

1.5 Magnetic Core Size

One of the most common ways to choose a core size is based on Area Product (AP), which is the product of the effective core (magnetic) cross-section area times the window area available for the windings.

Using a EE16/8 core and standard horizontal bobbin for this particular application, the equation used to estimate the minimum AP (in cm⁴) is shown as

$$AP = \left[\frac{L_p I_{prms}}{k_u B_{max} \Delta T^{0.5}} \right]^{1.316} \times 10^3$$

where,

L_p = Primary Inductance

I_{prms} = Primary RMS current

k_u = Window utilization factor, equal to:

- 0.4 for margin wound construction, and
- 0.7 for triple insulated wire construction

B_{max} = Saturation magnetic flux density

ΔT = Temperature rise in the core

1.6 Primary Winding

1.6.1 Winding Turns

The effective area of an EE16 core is 20.1mm² (in the core's datasheet). The number of turns of primary winding is calculated as

$$N_p = \frac{V_{DC(min)} D_{max}}{f_{s(min)} \Delta B A_e} = \frac{90 \times 0.5}{0.22 \times 20.1 \times 10^{-6} \times 57 \times 10^3} = 179$$

where,

N_p = Primary Winding Turns

$V_{DC (min)}$ = Minimum Input DC voltage

D_{max} = Maximum duty cycle

$f_{s(min)}$ = Minimum switching frequency

ΔB = Flux density swing

A_e = Effective area of the core

1.6.2 Wire Diameter

The current density (A_J) allowed to flow through the chosen wire is $4A/mm^2$. The Copper diameter of primary wire is expressed as

$$d_p = \sqrt{\frac{4I_{prms}}{A_J\pi}} = \frac{4 \times 0.062}{4 \times \pi} = 0.142\text{mm}$$

where,

d_p = Diameter of primary winding wire

I_{prms} = Primary RMS current

A_J = Current density

1.6.3 Number of Primary Winding Turns per Layer

The EE16 bobbin window is about 9mm, so if the enamel wiring chosen has a 0.21mm outer diameter and a 0.17mm Copper diameter, the number of turns per layer is expressed as

$$N_{p1} = \frac{90}{0.21} = 43$$

where,

N_{p1} = Layer 1 Primary Winding Turns

N_{p1} = 42 turns per layer, 4 layers needed

N_p = 168 (total turns for all 4 layers)

1.6.4 Practical Flux Swing

Using the $N_p = 168$ value, the practical flux swing is expressed as

$$\Delta B = \frac{V_{DC(min)}D_{max}}{f_{s(min)}A_eN_p} = \frac{90 \times 0.5}{168 \times 20.1 \times 10^{-6} \times 57 \times 10^3} = 0.234\text{T}$$

where,

ΔB = Flux density swing

$V_{DC(min)}$ = Minimum input bus voltage

D_{max} = Maximum duty cycle

$f_{s(min)}$ = Minimum switching frequency

A_e = Effective area of the core

N_p = Primary Winding Turns

1.7 Secondary Winding

Using triple insulation wire with a 0.21mm Copper diameter, the number of turns of secondary winding is expressed as

$$N_s = \frac{N_p}{N} = \frac{168}{14} = 12$$

where,

N_s = Secondary Winding Turns

N_p = 168 (total turns for all 4 primary winding layers)

N_p = Primary Winding Turns

N = Number of turns per primary winding layer

1.8 Auxiliary Winding

1.8.1 Winding Turns

The MOSFET gate voltage at minimum input voltage should be 10V to conduct the MOSFET completely. For this application, the optocoupler is powered by the fly-back method, so the number of auxiliary winding turns of auxiliary winding is calculated as

$$V_g = \frac{V_{DC(min)} N_a}{N_p} + \frac{(V_o + V_F) N_a}{N_s} > 10$$

where,

V_g = Gate voltage

$V_{DC(min)}$ = Minimum input bus voltage

N_a = Auxiliary Winding Turns

N_p = Primary Winding Turns

V_o = Optocoupler voltage

V_F = Fly-back voltage

N_s = Secondary Winding Turns

1.8.2 Wire Diameter

With the auxiliary winding turns set to 11 ($N_a = 11$), the enamel wire chosen has a 0.21mm outer diameter and a 0.17mm Copper diameter. The Copper diameter of primary wire is expressed as

$$N_a > \frac{10}{\frac{V_{DC(min)}}{N_p} + \frac{V_o + V_F}{N_s}} = \frac{10}{\frac{95}{168} + \frac{5.7}{12}} = 10$$

1.9 Gap Length

The gap length setting is based on the number of primary winding turns and primary inductance during the manufacturing process.

Note: In practice, the saturation current value must be ensured. If it is not, then the design activity should be restarted.

2 STD1LNK60Z-based RCC Control Circuit Components

2.1 MOSFET

The STD1LNK60Z (see [Appendix A: STD1LNK60Z-based RCC Circuit Schematics on page 22](#)) has built-in, back-to-back Zener diodes specifically designed to enhance not only the Electrostatic Discharge (ESD) protection capability, but also to allow for possible voltage transients (that may occasionally be applied from gate to source) to be safely absorbed.

2.2 R3 Startup Resistor

2.2.1 Minimum Power Dissipation

The startup resistor R3 is limited by its power dissipation because of the high input bus voltage that moves across it at all times. However, the lower the R3 value is, the faster the startup speed is. Its power dissipation should be less than 1% of the converter's maximum output power. The minimum power dissipation value is expressed as

$$\frac{V_{DC(max)}^2}{R_3} < 1\text{percent} \times \frac{V_o I_{o(max)}}{\eta}$$

$$R_3 > \frac{\eta V_{DC(max)}^2}{0.01 \times V_o I_{o(max)}} = \frac{0.7 \times 375^2}{0.01 \times 5 \times 0.48} = 4.1 \times 10^6 \Omega$$

2.2.2 Maximum Power Dissipation

If R3 is set to 4.2MΩ, its max power dissipation is expressed as

$$P_{R3(max)} = \frac{V_{DC(max)}^2}{R_3} = \frac{375^2}{4.2 \times 10^6} = 0.0335\text{W}$$

2.2.3 Startup Resistors and the Power Margin

The power rating for an SMD resistor with a footprint of 0805 is 0.125W. Three resistors (1.2MΩ, 1.2MΩ, and 1.8MΩ, respectively) are placed in series to produce the required startup resistor value and still have enough power margin.

2.3 Optocoupler Power Methods

There are two methods for powering the optocoupler:

- fly-back (see [Figure 2](#)), and
- forward (see [Figure 3](#)).

The fly-back method was chosen for the RCC application because it provides more stable power for the optocoupler.

Figure 2. Optocoupler Fly-back Power

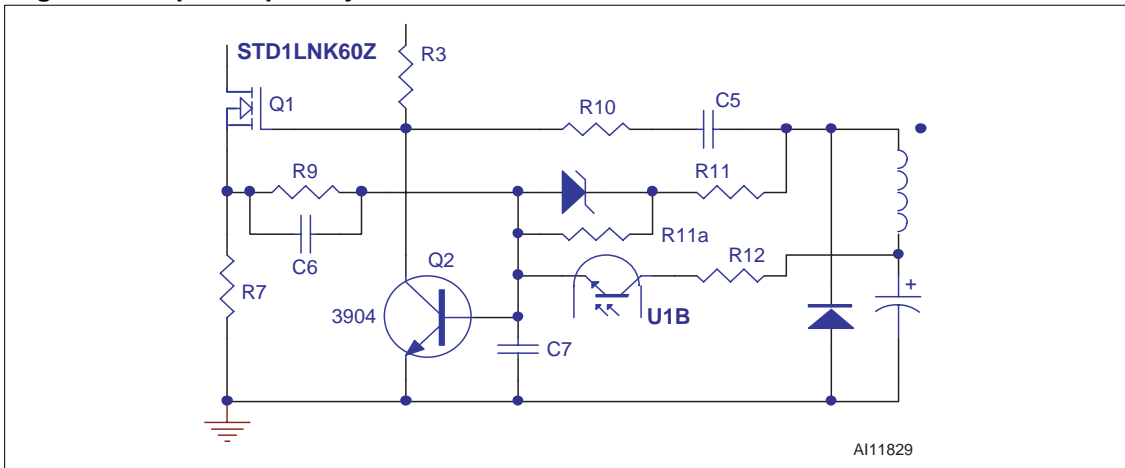

AI11829

Figure 3. Optocoupler Forward Power

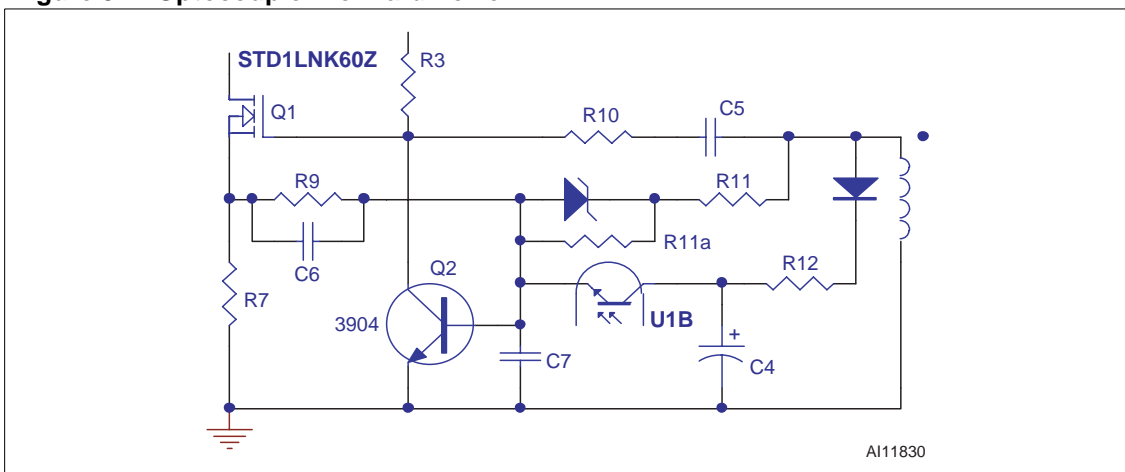

AI11830

2.4 R7 Sense Resistor

2.4.1 Minimum Power Dissipation

Sense resistor R7 is used to detect primary peak current. It is limited by its maximum power dissipation, which is set to 0.1% of the maximum power. The minimum power dissipation is expressed as

$$R_7 < \frac{0.01 \times V_o I_{o(max)}}{\eta I_{prms}^2} = \frac{0.01 \times 5 \times 0.48}{0.7 \times 0.062^2} = 8.9\Omega$$

2.4.2 Maximum Power Dissipation

If R7 is set to 3.4Ω, its maximum power dissipation is expressed as

$$P_{R7(max)} = I_{prms}^2 R_7 = 0.062^2 \times 3.4 = 0.013W$$

2.4.3 Sense Resistors and the Power Margin

Two resistors (6.8Ω, and 6.8Ω, respectively) are placed in parallel to produce the required sense resistor value and still have enough power margin.

Ramp-up voltage (via $R_7 \times I_{ppk}$), when added to the DC voltage $[(I_1 + I_e)(R_7 + R_9)]$ achieves good output voltage and current regulation (see [Figure 4](#)).

Note: The R9 value should be much greater than the R7 value. The minimum primary current, I_{ppk} , and the maximum current, I_2 , are in a steady state at the minimum load, while the maximum I_{ppk} and the minimum I_2 are in a steady state at the maximum load.

The cathode current, I_k , of TL431 is limited to $1mA < I_k < 100mA$, and the maximum diode current of optocoupler PC817 is 50mA. In order to decrease quiescent power dissipation, the maximum operation diode current, I_F of PC817 can be set to 10mA.

The Current Transfer Ratio (CTR) of PC817 is about 1:0 at the steady state. As a result, the maximum operation transistor current I_e of PC817 is also set to 10mA. Initially the effect of I_1 is neglected.

At minimum load,

$$R_7 I_{F(min)} + (R_7 + R_9) I_{e(max)} \approx (R_7 + R_9) I_{e(max)} \approx R_9 I_{e(max)} < V_{Qbe}$$

At maximum load,

$$R_7 I_{ppk} + (R_7 + R_9) I_{e(min)} \approx R_7 I_{ppk} + R_9 I_{e(min)} > V_{Qbe}$$

where,

V_{Qbe} = Cut off voltage; when the voltage between the base and the emitter of transistor Q2 reaches this value, MOSFET Q1 is turned off.

For the purposes of this application design:

$R_9 = 360\Omega$, and

$C_6 = 2.2nF$; the role of C_6 is to accelerate the MOSFET's turning OFF.

Figure 4. Current Sense Circuit

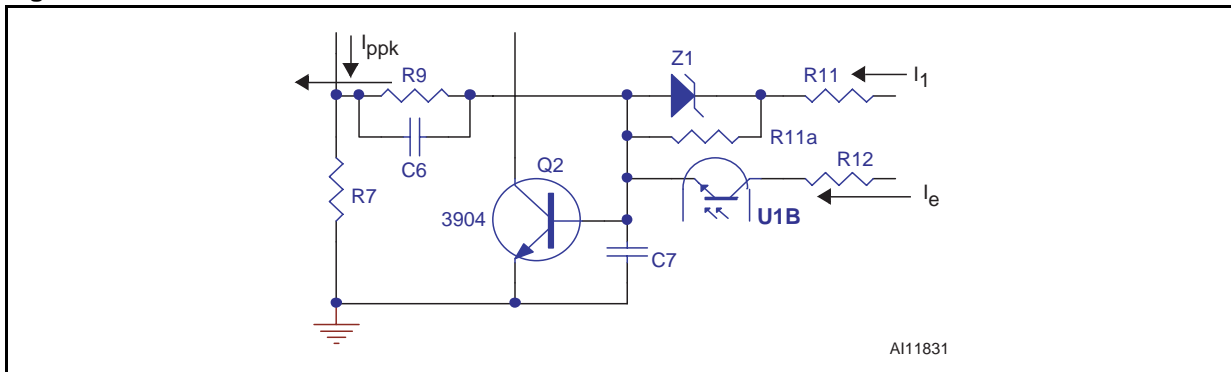

2.5 Constant Power Control

The pole of capacitor C7 can filter the leading edge current spike and avoid a Q2 switch malfunction. However, it will also lead to delays in primary peak transfer as well as the turning on of Q2. As a result, different power inputs are produced at different input voltages.

Z1, R11, and R11a provide constant current, which is proportional to the input voltage. This way, power inputs are basically the same at different input voltages.

Note: They must be carefully selected and adjusted to achieve basically constant power input at different input voltages. The basic selection process is expressed as

$$\Delta I = \frac{V_{DC} T_d}{L_p}$$

where,

ΔI = Current change

V_{DC} = Input bus voltage

L_p = Primary Inductance

T_d = Transfer delay

In relation to the present RCC application,

$$\Delta I R_7 = R_7 \frac{V_{DC} T_d}{L_p} = \frac{\frac{N_a V_{DC}}{N_p} + \frac{N_a (V_o + V_F)}{N_s} - V_{Z1}}{R_7 + R_9 + R_{11}} (R_9 + R_7)$$

where,

N_a = Auxiliary Winding Turns

N_p = Primary Winding Turns

V_o = Optocoupler voltage

V_F = Fly-back voltage

N_s = Secondary Winding Turns

V_{Z1} = Zener diode 1 voltage

Note: $R_{11} \gg R_9 \gg R_7$, so in this case, only R_{11} is used:

$$R_7 \frac{V_{DC}}{L_p} T_d \approx \frac{\frac{N_a V_{DC}}{N_p} + \frac{N_a (V_o + V_F)}{N_s} - V_{Z1}}{R_{11}} R_9$$

Note: Constant control accuracy is not as good if Z1 is not used, and applying it is very simple.

For the purposes of this application design:

$C_7 = 4.7\text{nF}$, and

$R_{11} = 36\text{k}\Omega$.

2.6 Zero Current Sense

C_5 blocks DC current during starting up and allow charge to be delivered from the input voltage through starting up resistor until MOSFET turns on for the first time. The MOSFET C_5 and input capacitor C_{iss} form a voltage divider at the MOSFET gate, so C_5 value should be ten times more than that of C_{iss} . This decreases the MOSFET (full) turn-on delay. In this case, $C_5 = 6.8\text{nF}$.

R_{10} limits power dissipation of zener diode inside the MOSFET. The selection process is expressed as

$$R_{10} = \frac{\left(\frac{V_{DC(max)} N_a}{N_p} + \frac{(V_o + V_F) N_a}{N_s} \right) - V_{ZD}}{I_{ZD}}$$

where,

$V_{DC(max)}$ = Maximum input bus voltage

N_a = Auxiliary Winding Turns

N_p = Primary Winding Turns

V_o = Optocoupler voltage

V_F = Fly-back voltage

N_s = Secondary Winding Turns

V_{ZD} = Zener diode voltage

I_{ZD} = Zener diode current

Note: If a 20V external zener diode is used and the maximum current of the zener diode is 10mA, the value of R_{10} is:

$R_{10} = 1.5\text{k}\Omega$

R_{12} limits current I_e of PC817, so the value of R_{12} is:

$R_{12} = 1\text{k}\Omega$

2.7 Constant Voltage And Constant Current

- The Constant Voltage (CV) configuration is comprised of the error amplifier TL431, R₂₁, R₂₂, and C₁₁. TL431 provides the reference voltage. R₂₁ and R₂₂ divide the output voltage and compare it with the reference. C₁₁ compensates the error amplifier TL431. R₁₉ limits the optocoupler diode current I_F (see [Figure 5](#) and [Figure 6 on page 18](#) for operation characteristics).

For the purposes of this application, the devices selected are:

$$R_{21}=1\text{k}\Omega;$$

$$R_{22}=1\text{k}\Omega;$$

$$C_{11}=100\text{nF}; \text{ and}$$

$$R_{19}=150\Omega.$$

- The Constant Current (CC) can be established simply with a transistor, Q3, R16, R18, R15, and C10. Output current flows through the sense resistor R16. Q3 is turned on when the voltage drop of R16 reaches the same value as the base turn-on voltage of Q3. This increases the current through the optocoupler and the converter goes into constant current regulation.

R16 senses the output current, and R18 limits the base current of Q3. The rating power of R16 must then be considered.

If I_o = 0.4A and V_b = 0.5V, then

$$R_{16} = \frac{V_b}{I_o} = \frac{0.5}{0.4} = 1.25\Omega$$

Two resistors, one 3.0Ω and one 2.2Ω, with SMD1206 footprint are placed in parallel to get the required power dissipation and resistance value.

Similarly, R15 limits the optocoupler's I_F diode current for constant current regulation. C10 compensates the constant current control.

For the purposes of this application, the devices are:

$$R_{15} = 75\Omega,$$

$$R_{18} = 360\Omega, \text{ and}$$

$$C_{10} = 1\text{nF}.$$

Note: The parameters of the remaining transformer devices can be seen in the Bill of Materials (BOM, see [Appendix B: STD1LNK60Z-based RCC Circuit Bill of Materials](#)).

Figure 5. CV and CC Curve at 110V_{AC}

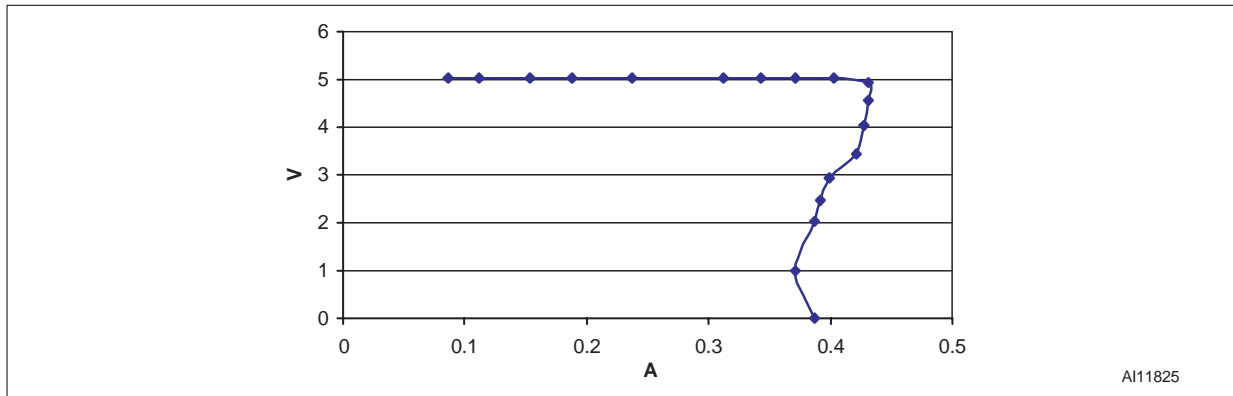

Note: $V_{DS} = 200V/div$; $time = 4\mu s/div$

Figure 6. CV and CC Curve at 220V_{AC}

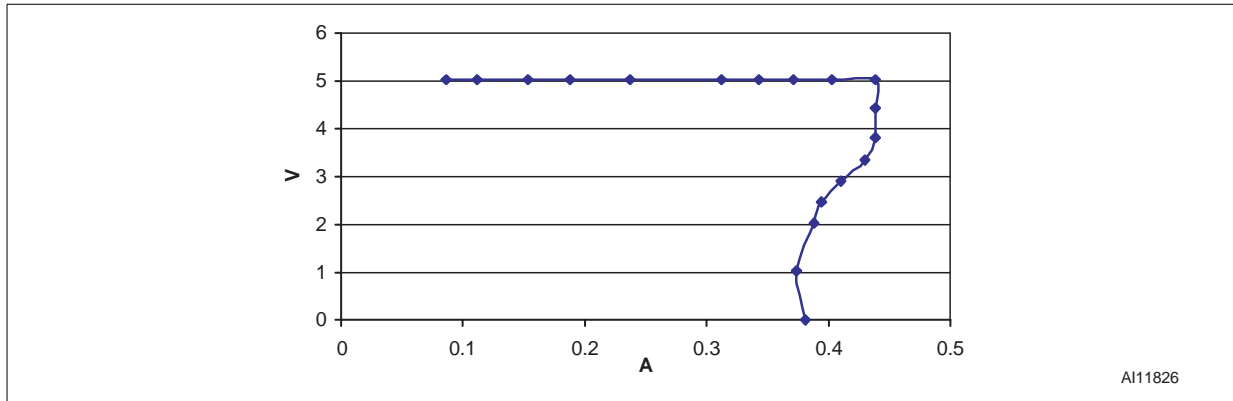

Note: $V_{DS} = 200V/div$; $time = 4\mu s/div$

3 Test Results

Table 1. Line and Load Regulation

Supply Voltage	No Load	Full Load	Load Regulation
85V _{AC}	4.749V	4.743V	±0.06%
110V _{AC}	4.750V	4.743V	±0.06%
220V _{AC}	4.750V	4.743V	±0.06%
265V _{AC}	4.750V	4.743V	±0.06%
Line Regulation			
	±0.01%	±0.0%	

Note: See [Figure 7](#) and [Figure 9](#) on page 21 for operation waveforms.

Table 2. Efficiency Ratings

Description	85V _{AC}	110V _{AC}	220V _{AC}	265V _{AC}	Units
Input power	2.754	2.706	2.918	3.006	W
Output voltage	4.743	4.743	4.743	4.743	V
Output current	0.4	0.4	0.4	0.4	A
Output power	1.9	1.9	1.9	1.9	w
Efficiency					
	69.0	70.2	65.1	63.2	%

Table 3. Standby Power

Input voltage	100V _{DC}	160V _{DC}	300V _{DC}	375V _{DC}
Input current	0.512A	0.224A	0.222A	0.242A
Input power	51mW	36mW	67mW	91mW

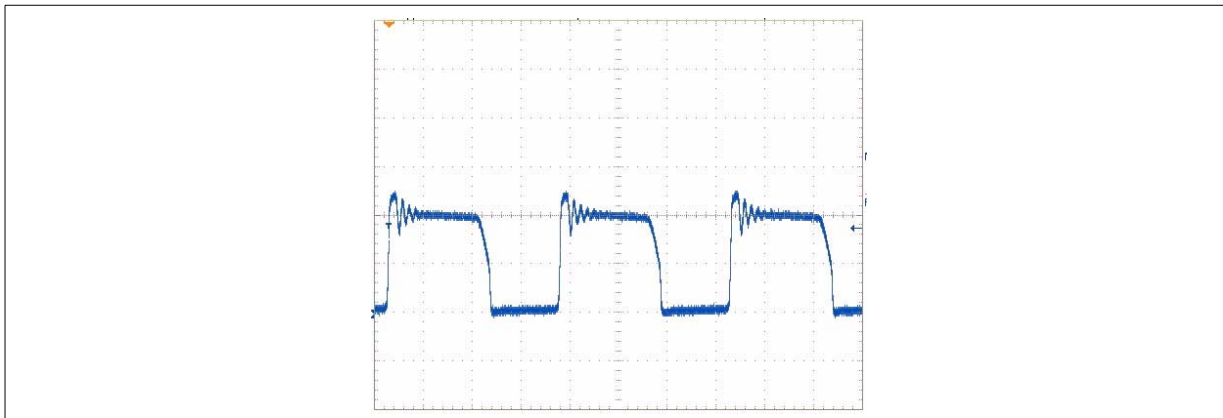
Figure 7. Drain To Source Voltage Operation Waveform, 85V_{AC}

Note: $V_{DS} = 100V/div$; time = $4\mu s/div$

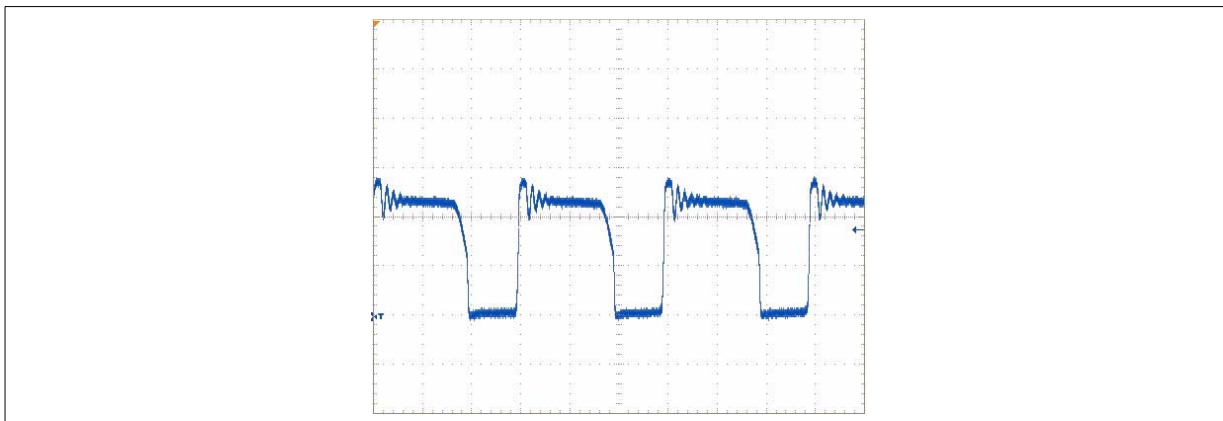
Figure 8. Drain To Source Voltage Operation Waveform, 110V_{AC}

Note: $V_{DS} = 100V/div$; time = $4\mu s/div$

Figure 9. Drain To Source Voltage Operation Waveform, 220V_{AC}

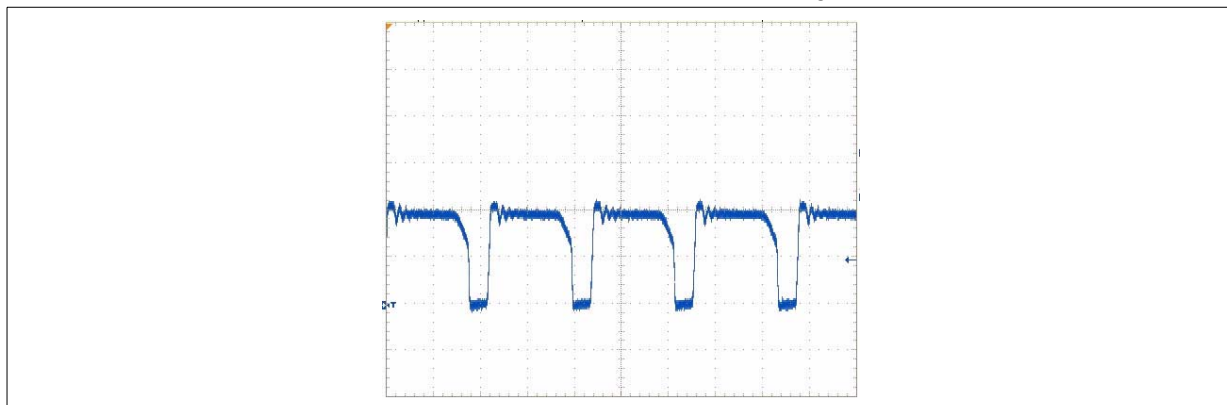

Note: $V_{DS} = 200V/div$; $time = 4\mu s/div$

Figure 10. Drain To Source Voltage Operation Waveform, 265V_{AC}

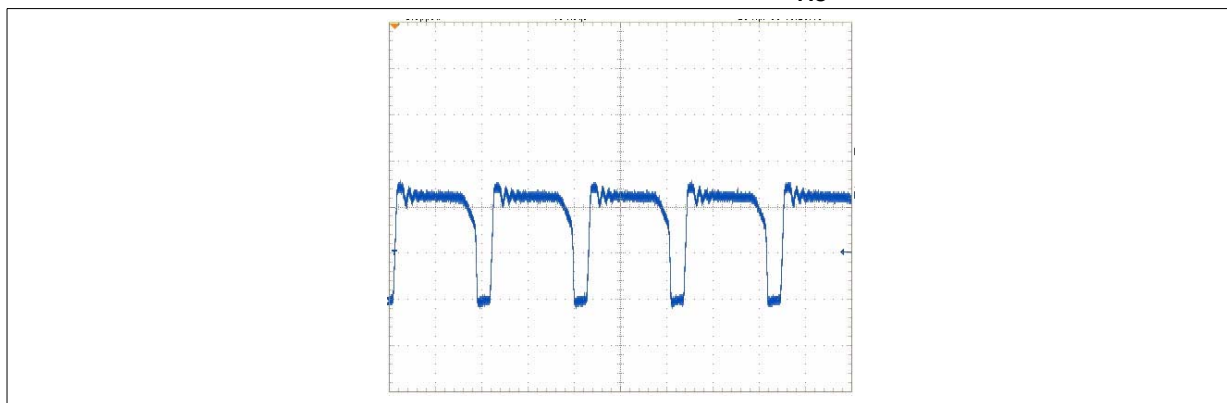

Note: $V_{DS} = 200V/div$; $time = 4\mu s/div$

Appendix A: STD1LNK60Z-based RCC Circuit Schematics

Figure 11. RCC Control Circuit Components Schematic (see Section 2 on page 12)

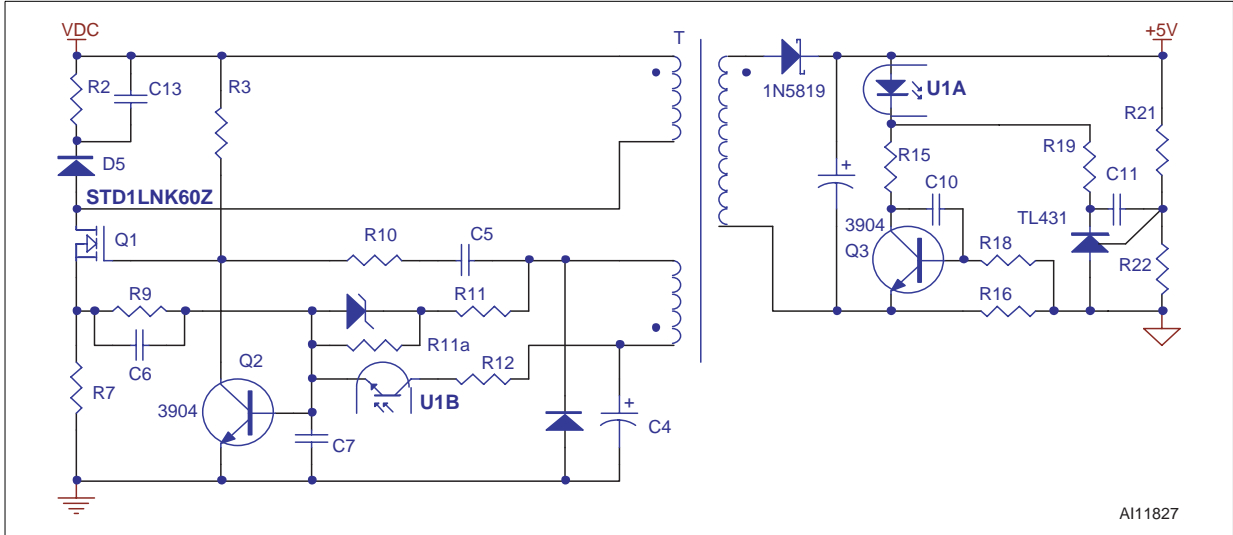
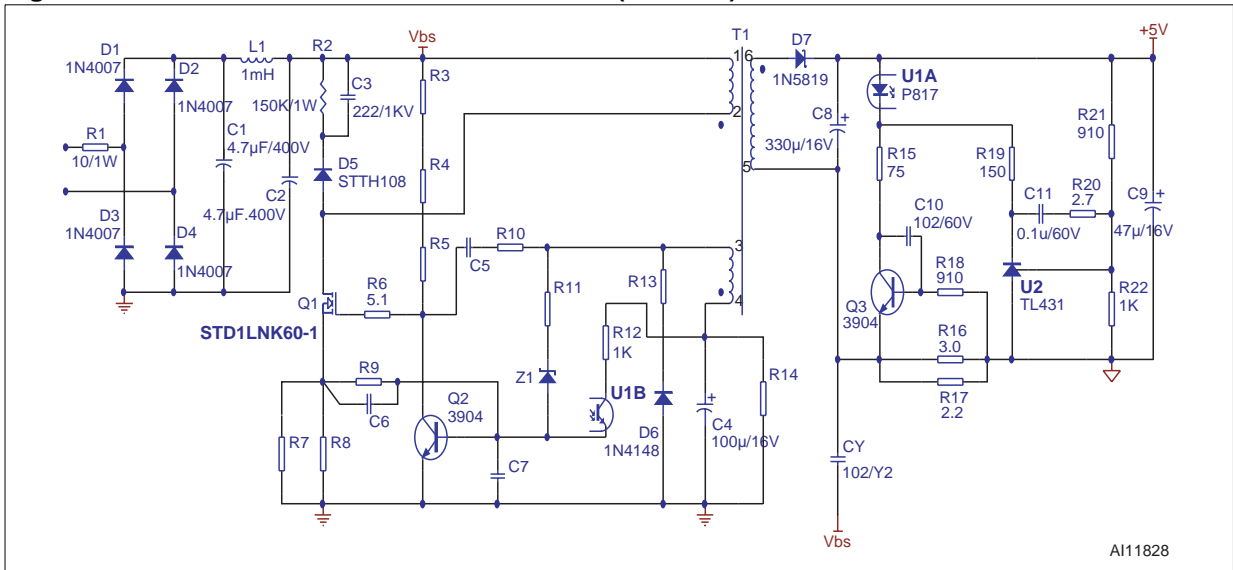

Figure 12. STD1LNK60Z-based RCC Schematic (full view)



Appendix B: STD1LNK60Z-based RCC Circuit Bill of Materials

Table 4. BOM

Designator	Part Type	Foot Print	Description	Accurate
L1	1mH		Inductor	
C1	4.7uF/400V		Electric Capacitor	85°C
C2	4.7uF/400V		Electric Capacitor	85°C
C3	222/1KV		Ceramic Capacitor	
C4	100u/16V		Electric Capacitor	105°C
C5	682/60V	0805A	SMD Capacitor	
C6	222/60V	0805A	SMD Capacitor	
C7	472/60V	0805A	SMD Capacitor	
C8	330u/16V		Electric Capacitor	105°C
C9	47u/16V		Electric Capacitor	105°C
C10	102/60V	0805A	SMD Capacitor	
C11	0.1u/60V	0805A	SMD Capacitor	
CY	102/Y2		Y2 Capacitor	
R1	10Ω/1W	1W	Resistor	10%
R2	150K/1W	1/2W	Resistor	10%
R3	1.8M	0805A	SMD Resistor	5%
R4	1.2M	0805A	SMD Resistor	5%
R5	1.2M	0805A	SMD Resistor	5%
R6	5.1Ω	0805A	SMD Resistor	5%
R7	6.8Ω	0805A	SMD Resistor	1%
R8	6.8Ω	0805A	SMD Resistor	1%
R9	360Ω	0805A	SMD Resistor	5%
R10	1.5K	0805A	SMD Resistor	5%
R11	36K	0805A	SMD Resistor	5%
R12	1K	0805A	SMD Resistor	5%
R13	5.1Ω	0805A	SMD Resistor	5%
R14	10K	0805A	SMD Resistor	5%
R15	75Ω	0805A	SMD Resistor	5%
R16	3Ω	1206R	SMD Resistor	1%
R17	2.2Ω	1206R	SMD Resistor	1%
R18	910Ω	0805	SMD Resistor	5%

Designator	Part Type	Foot Print	Description	Accurate
R19	150Ω	0805	SMD Resistor	5%
R20	2.7Ω	0805	SMD Resistor	5%
R21	910Ω	0805	SMD Resistor	1%
R22	1K	0805	SMD Resistor	1%
D1	1N4007	DO-41	Diode	
D2	1N4007	DO-41	Diode	
D3	1N4007	DO-41	Diode	
D4	1N4007	DO-41	Diode	
D5	STTH108	DO-41	Diode	ST
D6	1N4148		Diode	
D7	1N5819	DO-41	Diode	ST
Z1	Jumper		Jumper	
Q1	STD1LNK60	IPAK	MOSFET	ST
Q2	MMBT3904	SOT23L	Bipolar	ST
Q3	MMBT3904	SOT23L	Bipolar	ST
U1	P817	DIP4	Optocoupler	Sharp
U2	TL431	TO92L		ST

4 Revision History

Date	Revision	Changes
22-August-2005	1.0	First edition

Information furnished is believed to be accurate and reliable. However, STMicroelectronics assumes no responsibility for the consequences of use of such information nor for any infringement of patents or other rights of third parties which may result from its use. No license is granted by implication or otherwise under any patent or patent rights of STMicroelectronics. Specifications mentioned in this publication are subject to change without notice. This publication supersedes and replaces all information previously supplied. STMicroelectronics products are not authorized for use as critical components in life support devices or systems without express written approval of STMicroelectronics.

The ST logo is a registered trademark of STMicroelectronics.
All other names are the property of their respective owners

© 2005 STMicroelectronics - All rights reserved

STMicroelectronics group of companies

Australia - Belgium - Brazil - Canada - China - Czech Republic - Finland - France - Germany - Hong Kong - India - Israel - Italy - Japan -
Malaysia - Malta - Morocco - Singapore - Spain - Sweden - Switzerland - United Kingdom - United States of America

www.st.com